

Label-free non-contact glucose monitoring in organ-on-a-chip systems using NIR/MIR spectroscopy

V. Zubkovs¹, E. Möhr-Vorobeva¹, C. Beyer¹, A. Lovera², C. Bleich¹, S. Cattaneo¹

¹ CSEM SA, Landquart, Switzerland

² FEMTOPRINT SA, Agno, Switzerland



The PhotonMed consortium aims to advance photonics technologies for diagnostics, medical devices and wearables. CSEM is one among 39 consortium partner organizations in the consortium that go beyond state-of-the-art R&D to commercialize innovative photonics technologies. The application relevance and quality of the PhotonMed partner research will be validated in 16 pilot cases led by end-user companies. The research results from PhotonMed will be exploited by the end-user companies in their R&D towards the product launches.

EU Consortium PhotonMed

39 partners: Led by VTT Technical Research Center of Finland Ltd. Combination of large enterprises, SMEs, research organizations and universities to cover full development chain from concepting to industrial fabrication.

9 countries: Belgium, Cyprus, Finland, France, Germany, Ireland, Netherlands, Switzerland, Canada.

Objectives: The development of advanced photonics technologies is driven by the need for medical applications in diagnostics and personalized monitoring. Research work focuses on new components, integration technologies and new processes units for pilot line fabrication. The projects aims to:

- Introduce 10 new photonics component technologies, 11 integration technologies, and 3 new assembly units for pilot line fabrication.
- Demonstrate the significance of the research in 16 pilot cases led by the end-user companies.
- Accelerate the uptake of the advanced technologies using the pilot line operational model and ecosystem.

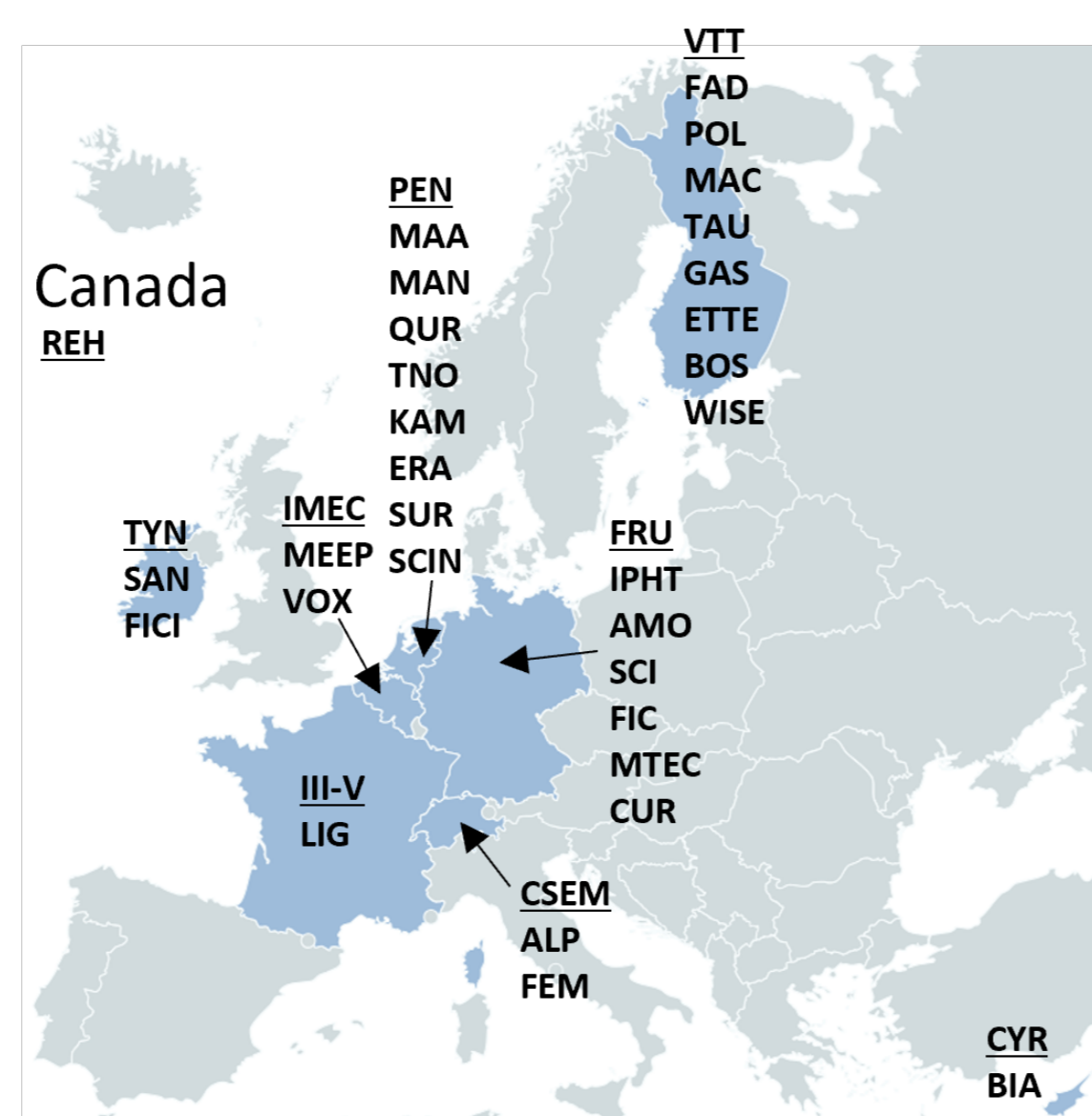

Pilot Case on Glucose Monitoring in OoC

Human organoid cultures in microfluidic organ-on-chip (OoC) systems can replicate human biological processes, thereby facilitating studies of organ physiology, inter-organ communication, and the pharmacological impacts of drugs on organs. These models hold significant promise for revolutionizing drug discovery by enabling efficient studies and the identification of novel drug targets, as well as testing drug interventions in physiologically relevant models. In this pilot case we will develop an innovative glucose monitoring device for OoC applications and demonstrate its functionality on a Liver-Pancreas-Assay by monitoring glucose concentration in cell culture compartment of the OoC.

Objective 1: Identify and integrate near-infrared (NIR) and mid-infrared (MIR) transparent materials which are suitable for *in vitro* applications in OoC devices.

Objective 2: Design and assemble a NIR/MIR demonstrator for glucose monitoring in OoC devices.

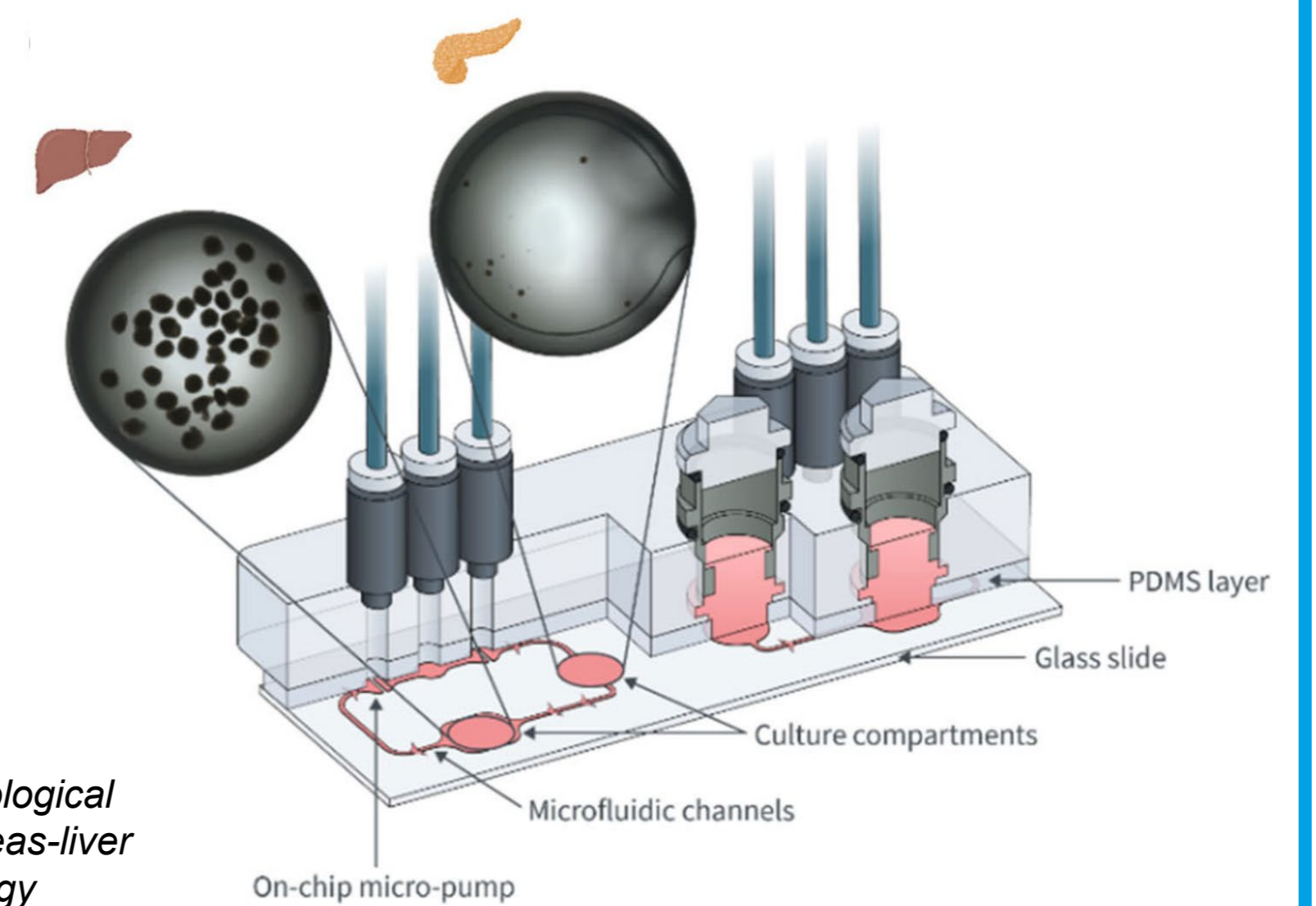

Figure source: S. Rigal, et al. Normoglycemia and physiological cortisone level maintain glucose homeostasis in a pancreas-liver microphysiological system (2024) Communications Biology

NIR Spectroscopy

Wavelength range:

- 1000–2500 nm or 10,000–4000 cm⁻¹

Typical bio-process monitoring targets:

- Glucose
- Albumin
- Lactate

Advantages:

- No or minimal sample preparation
- Instrumentation includes miniaturized readers
- Glass can be used as a sample container material
- Low instrumentation costs

Disadvantages:

- Overlapping contributions to the spectra of matrix
- Small absorptions signals changes
- Influence of ambient conditions (light, temperature)

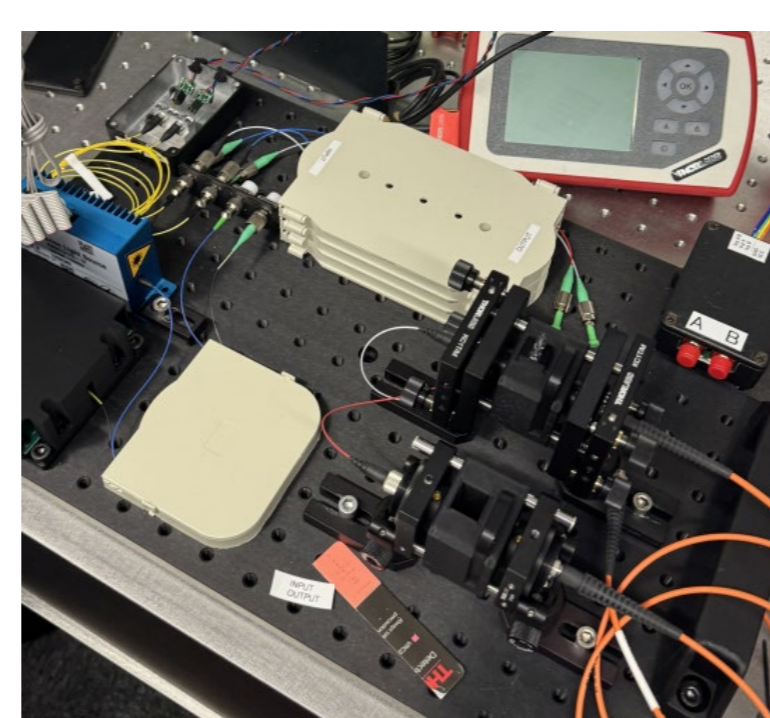

Prototype of a NIR spectroscopy setup developed at CSEM

System Design, Assembly, and Validation

CSEM is developing an integrated NIR/MIR spectroscopy system for OoC applications.

In collaboration with FEMTOPRINT, a fully integrated demonstrator will be designed and fabricated. This will include miniaturized sampling compartments integrated into an OoC device. These compartments are crucial for ensuring repeatable detection in long-term measurements.

1. Optics design and simulations

- Design of optical layout of the system
- Simulate performance optical using ray-tracing software, e.g. ZEMAX

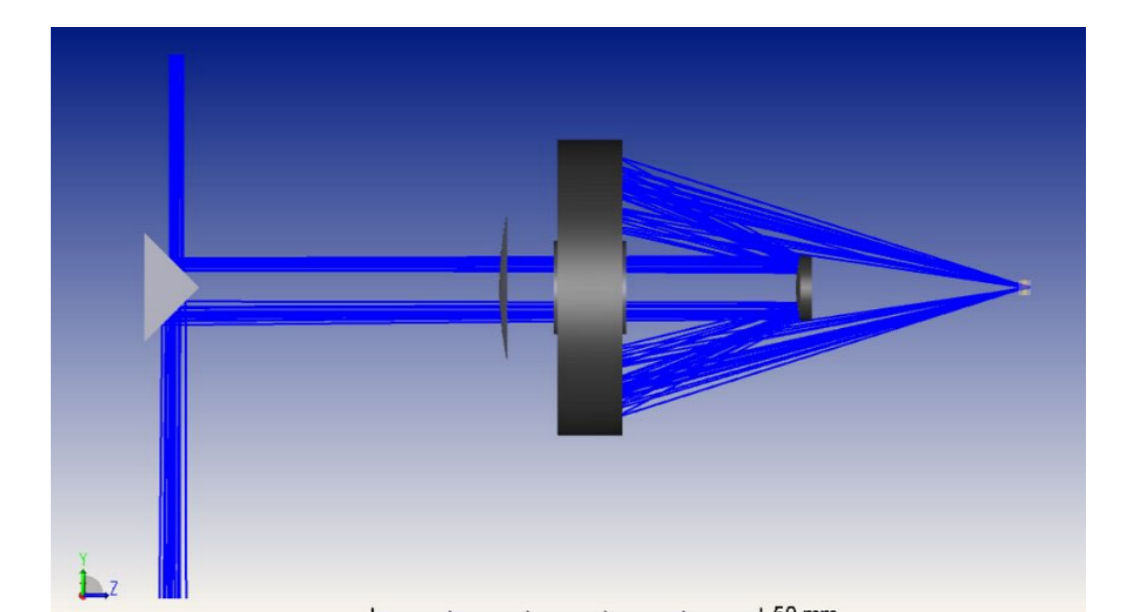

Optical simulation of the system components in ZEMAX software

2. Optical system hardware prototyping

- Integrate innovative optoelectronic components
- Improvement of SNR of the system
- Miniaturization and system integration

3. Optical system control software

- Software for driving optoelectronic components
- Signal processing algorithms
- Real-time data processing and visualization

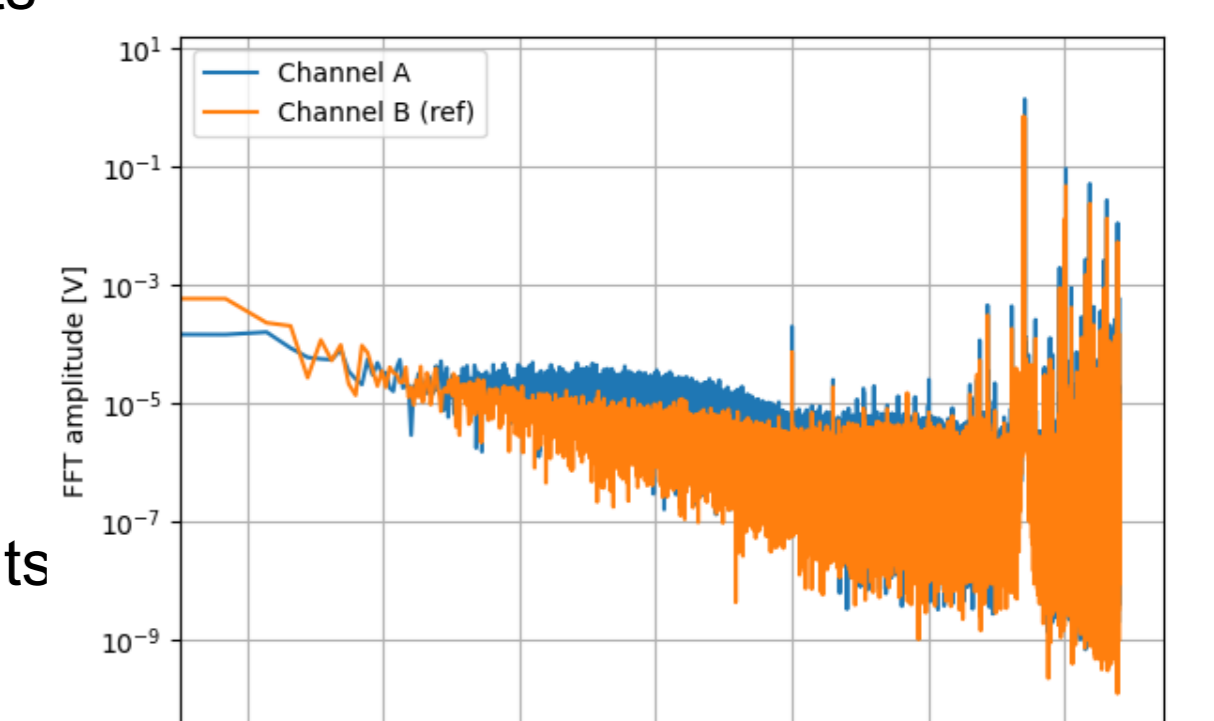

Signal processing using FFT

4. OoC device with integrated sampling inserts

- Design the sampling compartment with inserts compatible with the optical system
- Integration the sampling compartment in OoC device
- Validation of the setup for glucose monitoring
- Demonstrate the system functionality on a Liver-Pancreas-Assay

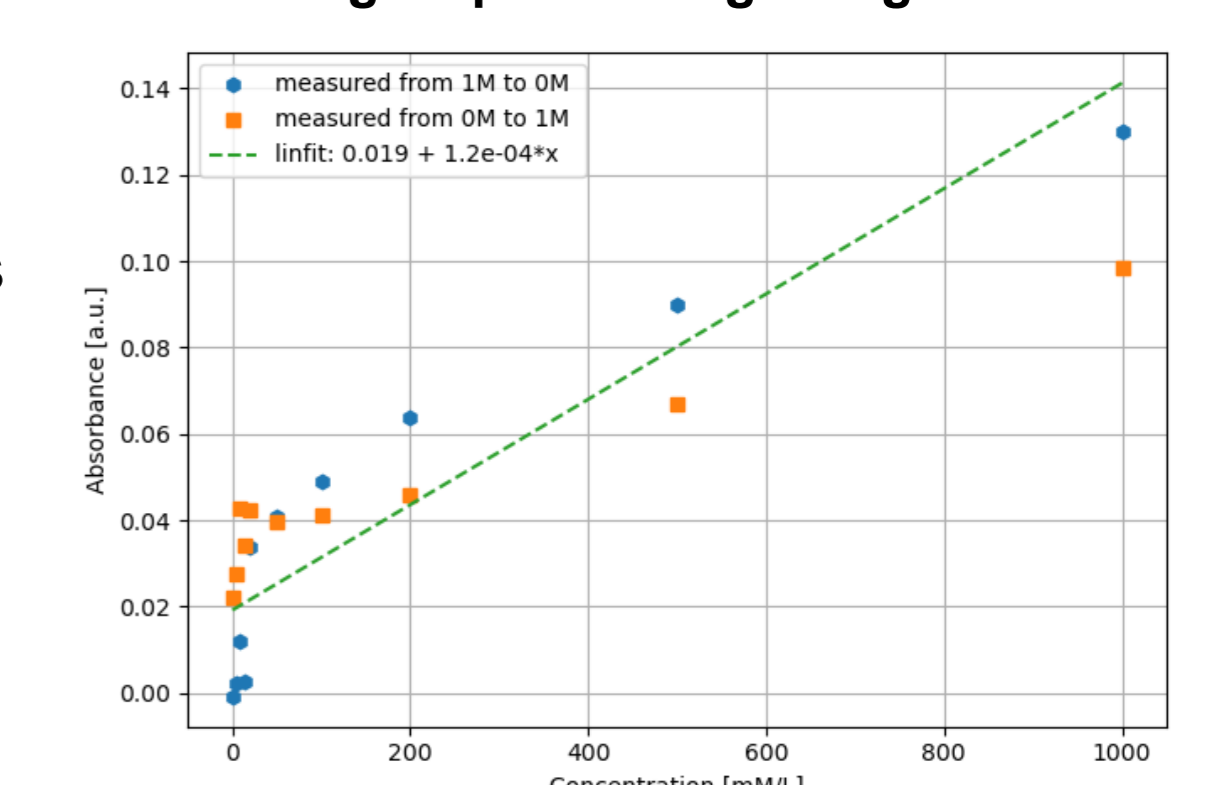

MIR Spectroscopy

Wavelength range:

- 2500–25,000 nm or 4000–400 cm⁻¹

Typical bio-process monitoring targets:

- Glucose
- Protein content
- Lactate

Advantages:

- Ability to analyze complex samples
- Negligible interference from ambient light
- High measurement dynamic range

Disadvantages:

- Strong interference from water in samples
- Sensing depth in water tens of micro-meter
- High instrumentation costs

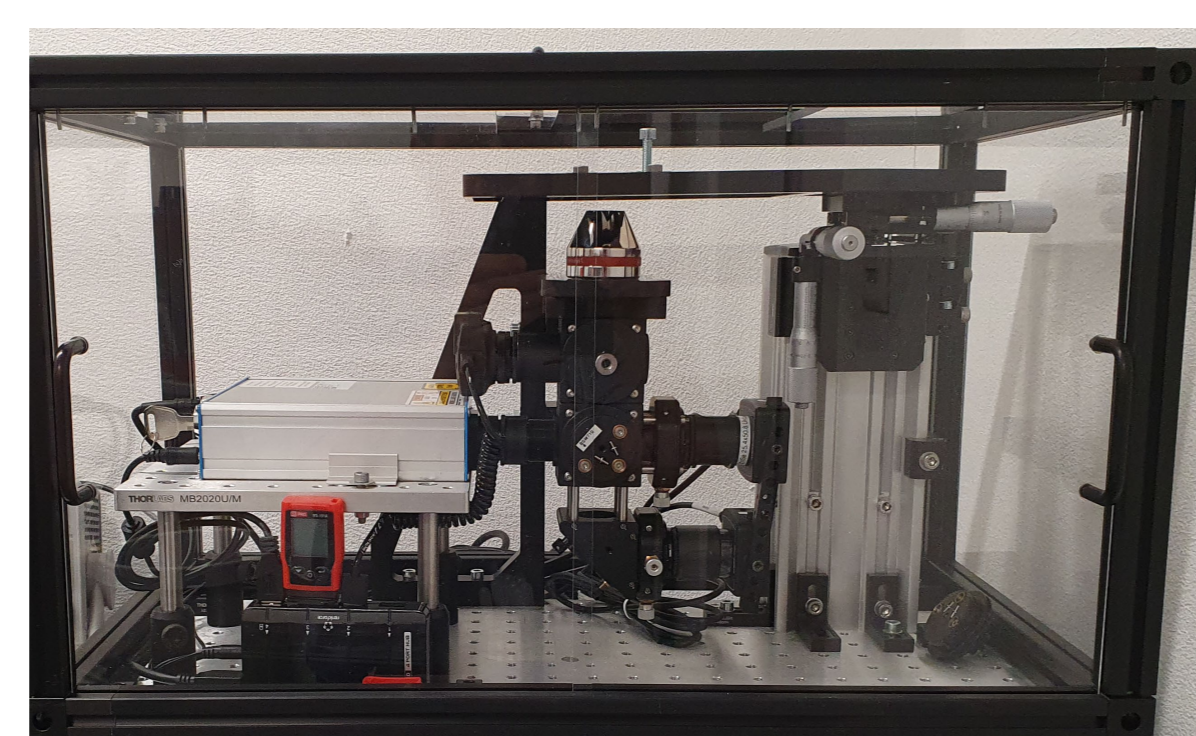

Poof-of-concept QCL-based MIR spectroscopy system developed at CSEM

